

# Oceanic Iron Ore Corp.

## Management's Discussion and Analysis of Financial Condition and Results of Operations Three months ended March 31, 2020 and 2019

---

The following discussion is management's assessment and analysis of the results and financial condition of Oceanic Iron Ore Corp. ("Oceanic" or the "Company") and should be read in conjunction with the accompanying audited consolidated financial statements and related notes for the year ended December 31, 2019. The Company reports its financial statements in accordance with International Financial Reporting Standards ("IFRS") as issued by the International Accounting Standards Board ("IASB"). All figures are reported in Canadian dollars unless otherwise indicated.

Certain information included in this discussion may constitute forward looking statements. Forward looking statements are based on current expectations and entail various risks and uncertainties. These risks and uncertainties could cause or contribute to actual results that are materially different from those expressed or implied. Please see the section entitled "Forward Looking Statements" of this document for further detail on forward looking statements. The effective date of this report is May 20, 2020.

### **Description of Business**

The Company was incorporated on March 8, 1986 under the British Columbia Business Corporations Act. Its common shares are traded on the TSX Venture Exchange.

The Company is focused on the exploration and development of the Ungava Bay iron property (the "Property") in Nunavik, Québec, which the Company acquired in November, 2010. The Property comprises three project areas: Hopes Advance (also referred to as the "Project" throughout), Morgan Lake and Roberts Lake, which cover over 170,468 hectares of iron formation and are located within 20 – 50 km of tidewater. The Company has a 100% interest, subject to a 2% net smelter returns royalty ("NSR") in the Property. The Company is currently focused on continuing its development of the Hopes Advance project through a Preliminary Economic Assessment study (described below) and environmental assessment as well as securing a strategic partner for the Hopes Advance project.

### **Hopes Advance Update – 2019 Re-Scoping PEA Study**

In December 2019, the Company announced the results of a revised and re-scoped National Instrument 43-101 Preliminary Economic Assessment in respect of the Company's Hopes Advance Project ("Study").

The objective of the PEA was to rescope the Project profile and production scale using Measured and Indicated Mineral Resources estimated within three of the 10 defined deposits from Hopes Advance in order to reduce the up-front capital required to bring the Project to commercial production.

### Background Information on the Study

The Study was led by the Montreal office of BBA, a Canadian consulting engineering firm with over 900 employees, who have extensive experience with iron ore projects, particularly in the Labrador Trough. Working alongside BBA was Wood (formerly, AMEC Foster Wheeler), who worked with the Company on Port related infrastructure in the Company's previous studies.

The Company presents two cases as part of the Study with the only variable between the cases being the FOB selling price. The Base Case assumes an FOB selling price of approximately USD \$82/t (approximately US \$105/t CFR). The alternate case presents the economics of the Project using a spot price of approximately USD \$89/t FOB (November 22, 2019).

In both cases, the Study is based on initial production of approximately 5 million tonnes per annum of dry concentrate followed by an expansion in year 5 to approximately 10 million tonnes per annum. The financial analysis for the Study is limited to a 28-year mine life and considers only 3 of the 10 deposits for which mineral resources have been estimated. The Company believes that the remaining resources could support continued operations well beyond 28 years. The 28 year mine plan for the Study is based on mining the

# Oceanic Iron Ore Corp.

## Management's Discussion and Analysis of Financial Condition and Results of Operations Three months ended March 31, 2020 and 2019

Castle Mountain, Iron Valley and Bay Zone F deposits. For both initial and expansion phases of the Study, power is self-generated using diesel fuel. Concentrate is filtered at the concentrator site and transported year-round by truck to a port stockpile where it is shipped only during summer months. Such seasonal shipping results in reduced port installation costs and the avoidance of having to use higher cost ice class vessels during the winter. For the Study, BBA proposed a modified process flowsheet which is more energy efficient, aimed at reducing power requirements (and fuel storage) and expected to improve the Project's carbon footprint.

### Key Metrics & Attributes

Table of Key Metrics of the Study

Description	Base Case	Spot Case	2012 PFS
Mine Life (years)	28	28	31
LoM Concentrate Production (mt)	262	262	507
Concentrate Fe Grade	66.6%	66.6%	66.5%
Weight Recovery	38%	38%	38%
FOB Selling Price/t (USD)	82.14 \$	88.83 \$	100.00 \$
<b>Key Financial Metrics (All CAD\$)</b>			
Opex/t	\$ 30.70	\$ 30.70	\$ 30.18
Initial Capex (\$ million)	1,193 \$	1,193 \$	2,854 \$
Expansion Capex (\$ million)	690 \$	690 \$	1,608 \$
Sustaining Capex (\$ million)	632 \$	632 \$	767 \$
LoM Capex (\$ million)	2,515 \$	2,515 \$	5,229 \$
<b>Pre-Tax Economics</b>			
NPV8 (\$ million)	2,377 \$	2,919 \$	5,632 \$
IRR	21%	23%	21%
NPV / Initial Capex	1.99	2.45	1.97
NPV / Initial& Expansion Capex	1.26	1.55	1.26
<b>Post-Tax Economics</b>			
NPV8 (\$ million)	1,405	1,744	3,152
IRR	17%	19%	17%
NPV / Initial Capex	1.18	1.46	1.10
NPV / Initial& Expansion Capex	0.75	0.93	0.71

\* Numbers may not add up due to rounding. The PEA is based on Mineral Resources. Mineral Resources that are not Mineral Reserves do not have demonstrated economic viability. The mine plan is based on Mineral Resources that have not been classified as Mineral Reserves, and there is no certainty that the PEA based on these Mineral Resources will be realized.

Additional attributes and / or metrics of Hopes Advance include the following:

- Located on the coast, no rail infrastructure—significant capital and operating cost savings

# Oceanic Iron Ore Corp.

## Management's Discussion and Analysis of Financial Condition and Results of Operations Three months ended March 31, 2020 and 2019

---

- No dependency on 3rd party owned infrastructure such as rail, port and power, including extension to the Hydro Québec grid north to the Project (Construction and operations to utilize barge-mounted self-generated power)
- Seasonal shipping of concentrate versus year-round shipping, reducing Port infrastructure capital costs and eliminating winter shipping risks
- 1.4 billion tonne Measured & Indicated Mineral Resource
- Low mining costs with a low strip ratio of 0.81:1
- Low operating cost per tonne resulting from “no rail” advantage, simple metallurgy and low strip ratio (0.81:1 over life of mine)
- Construction of a marine facility in Hopes Advance Bay at Pointe Breakwater
- Only 3 of 10 deposits (previously evaluated in the 2012 Pre-feasibility Study) at Hopes Advance considered in PEA; Potential for life of mine extension beyond 28 years
- High weight and iron recoveries with simple flow sheet
- Extensive bench scale and pilot plant testing demonstrate high quality product with 4.5% silica, very low other impurities and 66.6% iron grade

### Capital Costs

Construction and Sustaining Capital Costs are set out below. The capital costs profile in the Study has been scaled back to conform to the reduced production profile of the Project. Considering that concentrate is trucked to the port and not pumped, this eliminates costs related to regrinding and drying the concentrate. Furthermore, a strategy of leasing the mining, site service and concentrate hauling equipment and the barge-based power plant has been adopted in the Study. This transfers costs from capital costs to operating costs.

# Oceanic Iron Ore Corp.

Management's Discussion and Analysis of Financial Condition and Results of Operations  
Three months ended March 31, 2020 and 2019

Table - Capital Costs from the Study

Category	Initial Phase	Expansion	Sustaining
	M\$	M\$	M\$
Mining Equipment Fleet	-	48	359
Mining (Capitalized Pre-Stripping)	23	-	-
Project Direct Costs			
Mineral Processing Area	207	210	-
TMF (Dyke Construction)	12	7	96
Port Area	182	73	-
Mine Site Infrastructure and Services	159	41	8
Port Site Infrastructure and Services	27	33	-
Electric Power	48	28	-
Other Capitalized Pre-Production Costs	50	18	70
<b>Total Direct Costs</b>	<b>707</b>	<b>457</b>	<b>533</b>
Indirect Costs (including Owner's Costs)	266	118	29
Contingency	187	115	27
Closure and Rehabilitation Costs	33	-	44
<b>Total</b>	<b>1 193</b>	<b>690</b>	<b>632</b>

\* Numbers may not add up due to rounding.

## Operating Costs

A summary of the estimated operating costs is set out below:

Table 8 – Operating Costs (Excluding Royalties)

Category	Initial Phase	Expansion	Avg. (LOM)
	\$/t conc.	\$/t conc.	\$/t conc.
Mining	\$9.38	\$10.53	\$10.44
Mineral Processing	\$10.93	\$10.53	\$10.56
Concentrate Transport to Port Stockpile	\$1.98	\$1.98	\$1.98
Port (Concentrate Handling and Shiploading)	\$3.99	\$2.32	\$2.44
General Site Services	\$4.83	\$3.11	\$3.24
Administration	\$1.77	\$1.08	\$1.13
<b>Total Opex (excluding leased equipment)</b>	<b>\$32.88</b>	<b>\$29.55</b>	<b>\$29.80</b>
Leased Equipment	\$5.62	\$0.51	\$0.90
<b>Total Opex</b>	<b>\$38.50</b>	<b>\$30.06</b>	<b>\$30.70</b>

\* Numbers may not add up due to rounding.

# Oceanic Iron Ore Corp.

Management's Discussion and Analysis of Financial Condition and Results of Operations  
Three months ended March 31, 2020 and 2019

---

The low operating costs are a function of a number of factors including:

- No rail component given the project's proximity to the identified port site at Pointe Breakwater.
- A low strip ratio, averaging 0.81:1 over the life of mine.
- Straightforward metallurgy and high Fe recoveries.

Operating Costs exclude the 2% royalty payable to the previous holders of the Project. The Study assumes that the Company will exercise its right to purchase half of this royalty for \$3 million at the commencement of commercial production.

## Metallurgical Testwork and Process Flowsheet

Metallurgical testwork consisted of bench scale tests as well as a pilot test program. Generally, the results of the testwork indicated the following characteristics for the mineralized material tested:

- It is relatively soft
- It can be processed with a simple and conventional flow sheet
- A concentrate with low SiO<sub>2</sub> and low deleterious elements can be produced

The conceptual flowsheet and plant design proposed in the Study are based on the following:

- Testwork performed in 2012.
- A comminution circuit based on HPGR grinding technology.
- The use of a three-stage spiral circuit for gravity concentration.
- A scaled version of the magnetic concentrator plant, substituting the Ball Mill with more energy efficient Verti-Mills.
- Flowsheet improvements, plant design and general layouts based on BBA's experience on other similar projects.
- Concentrate trucking to the port removing the requirement of regrinding the hematite concentrate and construction of a pipeline.

A simplified mineral processing flowsheet is shown below.

# Oceanic Iron Ore Corp.

Management's Discussion and Analysis of Financial Condition and Results of Operations  
Three months ended March 31, 2020 and 2019

Simplified flowsheet for comminution and spiral circuits

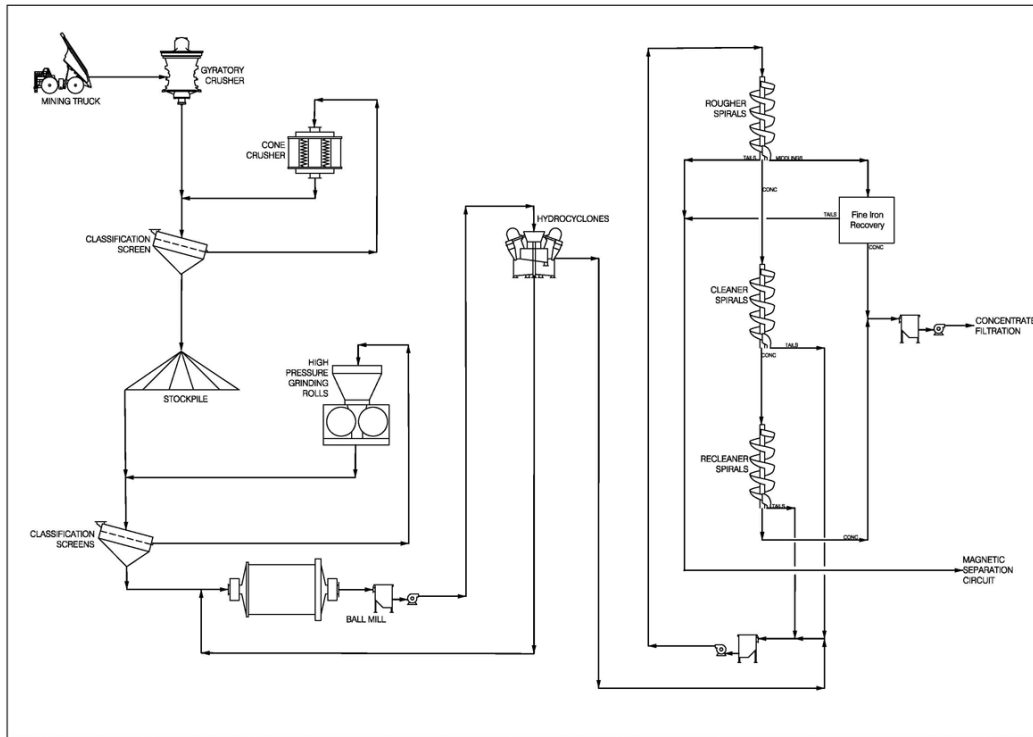

Simplified flowsheet for magnetic separation, regrind and dewatering circuits

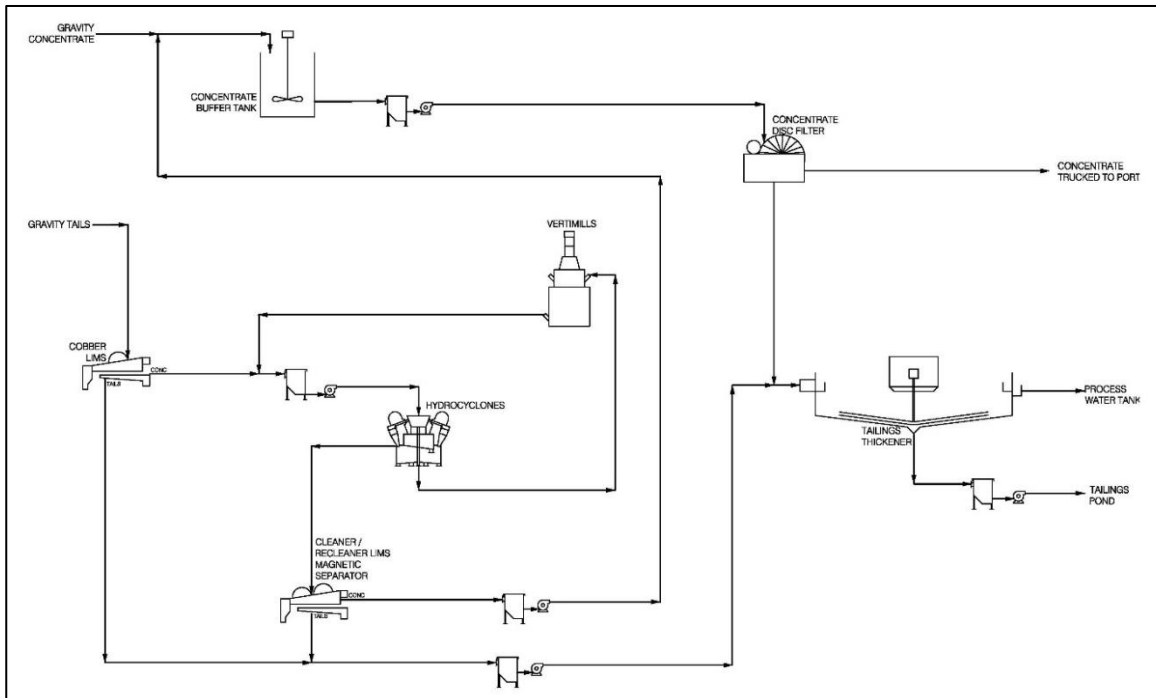

# Oceanic Iron Ore Corp.

Management's Discussion and Analysis of Financial Condition and Results of Operations  
Three months ended March 31, 2020 and 2019

---

A description of the proposed process is set out below:

- Run of mine mill feed material is crushed in two stages prior to being stockpiled;
- Crushed mill feed material will be reclaimed and undergoes a size reduction to a P80 of 140µm via HPGR and ball milling;
- The material is then pumped to a gravity recovery circuit which produces a final hematite concentrate and a gravity tail;
- The gravity tails are pumped to magnetic separation wherein the magnetic portion is recovered and sent to filtration along with the hematite concentrate;
- The tailings from magnetic separation are thickened and pumped to a tailings pond;
- The filtered concentrate is stockpiled to be loaded year-round into trucks which transport the concentrate to a stock yard where a stacker-reclaimer system will place the material into a storage stockpile to be shipped during the summer season;

## Mineral Resource Estimate

The Hopes Advance iron deposits comprise a total of 10 mineral deposits. These deposits are a typical stratigraphic iron deposit similar to other Labrador Trough iron deposits of Lake Superior-type iron formations, located at the northern end of the Labrador Trough.

The Hopes Advance iron formations are thick Sokoman Iron Formation, with magnetite, magnetite and hematite units that strike east-west to northeast and have gentle dips to the south and southeast. The iron formations are typically 40–70 m thick, and often outcrop at surface. The three largest deposits are the Castle Mountain, Bay Zone F and Iron Valley deposits.

Mineral Resources that were estimated assuming open pit mining methods in 2012 were reviewed in 2019 to determine if they were still current. These reviews included checks on the confidence classification assignments based on changes to defined terms between the 2010 and 2014 editions of the Canadian Institute of Mining, Metallurgy and Petroleum (CIM) Definition Standards for Mineral Resources and Mineral Reserves, inputs into the Whittle optimisation shells that constrain the estimate, and commodity price assumptions as a result of the 2019 VIU Study. Eddy Canova, P. Geo, a consultant to the Company concluded that the estimates remain current, and have an effective date of 20 November, 2019, which is the date the reviews were completed.

Mineral Resources were estimated for the Bay Zone B, C, D, E, F, Castle Mountain, Iron Valley, West Zone 2, West Zone 4 and West Macdonald deposits, and are totalled in Table 3.

Mineral Resource Estimate Hopes Advance (25% Fe Cut-off)

Classification	Tonnes	Fe	Concentrate
	(t 000)	(%)	Tonnes (t 000)
Measured	774,241	32.2	288,971
Indicated	613,796	32.0	226,901
<b>Measured &amp; Indicated</b>	<b>1,388,037</b>	<b>32.1</b>	<b>515,872</b>
Inferred	222,188	32.5	82,475

# Oceanic Iron Ore Corp.

## Management's Discussion and Analysis of Financial Condition and Results of Operations Three months ended March 31, 2020 and 2019

---

### Notes:

1. *The Qualified Person responsible for the estimates (including the current Mineral Resource estimates) is Mr. Eddy Canova, P. Geo, a consultant to the Company.*
2. *Mineral Resources are reported assuming open pit mining methods. Mineral Resources were initially reported with an effective date of 19 September 2012, on a block model that had an effective date of 2 April 2012. A review was undertaken in 2019, which concluded that the estimate and its inputs were current, and the effective date for the reviewed estimate is 20 November, 2019. The Mineral Resource is now current as at November 20, 2019*
3. *Mineral Resources are classified using the 2014 CIM Definition Standards. Mineral Resources are not Mineral Reserves and do not have demonstrated economic viability.*
4. *The Mineral Resources were estimated using a block model with parent blocks of 50 m by 50 m by 15 m sub-blocked to a minimum size of 25 m by 25 m by 1m and using inverse distance weighting to the third power (ID3) methods for grade estimation. A total of 10 individual mineralized domains were identified and each estimated into a separate block model. Given the continuity of the iron assay values, no top cuts were applied. All resources are reported using an iron cut-off grade of 25% within conceptual Whittle pit shells and a mining recovery of 100%. The Whittle shells used the following input parameters: commodity price of USD \$115/dmt of concentrate; C\$:US\$ exchange rate of 0.97; assumed overall pit slope angle of 50°; 1% royalty; mining cost of CAD \$2.00/t material moved; process cost of CAD \$16.22/t of concentrate; port costs of CAD \$1.45/t of concentrate; and general and administrative costs of CAD \$3.38/t of concentrate.*
5. *Estimates have been rounded and may result in summation differences.*

### **Mine Plan**

The proposed mining method selected for the Project consists of a conventional open pit, truck and shovel, drill and blast operation. The mineralized material and waste rock will be mined with 10 m high benches, drilled, blasted and loaded into a fleet of 292 t capacity haul trucks with diesel hydraulic shovels.

The mineralized material will be hauled to the primary crushing facility and the waste rock will be hauled to either the waste rock piles or to the tailings facility to be used as construction material.

Even though the Hopes Advance Bay Mineral Resources are contained within ten (10) distinct deposits, the Study is limited to the Castle Mountain, Iron Valley, and Bay Zone F deposits. These three deposits provide sufficient material to sustain the first 28 years of operation at the production rate considered in the Study. Each of these deposits has favorable economics (higher grade and lower strip ratios than the other deposits) and they are also the three largest resource bases of the ten deposits. Only mineral resources classified as Measured and Indicated are considered in the mine plan as potential mill feed.

Table 4 below presents the subset of the Mineral Resources that are contained within the open pit designs that were used to develop the life of mine plan for the Study. The resource subset is reported above a cut-off grade of 25% Fe and includes mining dilution and mining losses which were estimated to be 1.5% and 5% respectively.



# Oceanic Iron Ore Corp.

Management's Discussion and Analysis of Financial Condition and Results of Operations  
Three months ended March 31, 2020 and 2019

Table 4: Subset of Mineral Resources within the PEA mine plan (25% Fe Cut-Off Grade)

Deposit	Measured Resources			Indicated Resources			Total Resources			Waste	Strip Ratio
	Tonnes	Fe	WR	Tonnes	Fe	WR	Tonnes	Fe	WR	Tonnes	
	(Mt)	(%)	(%)	(Mt)	(%)	(%)	(Mt)	(%)	(%)	(Mt)	
Castle Mountain	266	32.6	38.0	107	32.6	38.0	372	32.6	38.0	317	0.85
Iron Valley	34	34.1	40.0	57	33.9	40.0	91	34.0	40.0	62	0.68
Bay Zone F	107	33.0	39.0	114	32.7	38.0	221	32.8	38.5	178	0.80
<b>Total</b>	<b>406</b>	<b>32.8</b>	<b>38.4</b>	<b>278</b>	<b>32.9</b>	<b>38.4</b>	<b>684</b>	<b>32.9</b>	<b>38.4</b>	<b>557</b>	<b>0.81</b>

\* Numbers may not add up due to rounding.

## Processing Plan

The Process design basis for both the initial and expansion phases of the Study is outlined in Table 5.

Table 5: Proposed process design basis

Parameter	Unit**	Initial Phase*	Expansion Phase*
Total feed processing rate	Mtpa	13.3	26.5
Weight recovery (per project phase)	%	39.1%	38.2%
Weight recovery (LOM)	%	38.4%	
Concentrate produced (Total)	Mtpa	5.18	10.13
Concentrate produced (gravity ~ 84%)	Mtpa	4.35	8.51
Concentrate produced (magnetic ~ 16%)	Mtpa	0.83	1.62
Final Concentrate Grade (%Fe , % SiO <sub>2</sub> )	%	66.6% Fe, 4.50% SiO <sub>2</sub>	

\* Initial Phase from Yr 1 to Yr 4. Expansion Phase from Yr 5 to Yr 28. Excludes ramp-up years Yr 1 & Yr 5.

\*\* All tonnages are in dry metric tonnes.

## Updated Marketing Study

In 2013, the Company commissioned and received a Product Value in Use Marketing Study (“**2013 VIU Study**”) from Vulcantech Technologies. The 2013 VIU Study concluded that, in addition to the iron unit premium for the high grade Hopes Advance product at 66.6% Fe measured against the 62% Fe benchmark, the low impurities associated with the Hopes Advance product could attract an additional quality premium for steel producers in China, Korea, Japan, and Taiwan.

In 2019, the Company commissioned Vulcantech Technologies to update its VIU study (the “**2019 VIU Study**”) in order to obtain current market data as to the potential pricing and demand for Hopes Advance Iron Ore.

# Oceanic Iron Ore Corp.

## Management's Discussion and Analysis of Financial Condition and Results of Operations Three months ended March 31, 2020 and 2019

---

The 2019 VIU Study concludes that:

- Recent environmental restrictions placed by Chinese Central and Provincial Governments are likely to lead to more support for higher grade iron ores as steel mills try to maximize steel production and minimize pollution, driven by chemical inputs used in removing deleterious elements from iron ore
- 65% Fe index ores are expected to obtain a 15-30% premium per Fe unit over the 62% Fe benchmark prices
- The quality premium over and above the 65% Fe index ores has been reduced to approximately 5%
- Due to the above, improved pricing compared to the base case pricing used for the Study would be expected given the low phosphorus and alumina content of the Hopes Advance material
- While the 2019 VIU Study focuses on Chinese demand, steel producers in China, Korea, Japan, Taiwan and Europe could still benefit considerably from the product's low impurity chemistry.

### Environmental Permitting

To date, all of the terrestrial baseline work for the Environmental Impact Assessment has been completed. The outstanding components include marine baseline data inventories and additional consultations with relevant stakeholders.

A time sensitive migratory bird survey was completed during May 2016. Further, in September 2016, the Company completed baseline data collection focused on marine mammals, fish studies, water quality, and mollusk habitat. With the insights obtained from baseline data collection and environmental studies the Company will engage in additional future dialogue with Inuit stakeholders in the region to optimize the Project's benefits and minimize the impacts associated with the Project's construction and subsequent operations.

### Next Steps

In the coming months, the Company will be focused on securing a strategic partner for Oceanic to further advance the Project as well as securing additional financing to allow for the above.

Eddy Canova, P.Geo., OGQ(403), a Qualified Person as defined by NI 43-101, has reviewed and is responsible for the technical information contained in this document.

### Overall Performance and Results of Operations

Total assets increased to \$43,792,377 at March 31, 2020 from \$43,774,328 at December 31, 2019. The most significant assets at March 31, 2020 were mineral properties of \$43,423,991 (December 31, 2019: \$42,324,901), and cash and cash equivalents of \$315,587 (December 31, 2019: \$422,788). The Company's working capital deficit at March 31, 2019 was \$703,310 (December 31, 2019: \$480,467).

The increase in mineral properties of \$99,090 largely reflects accretion of the Company's advance royalty payable as well as costs associated with the Study, which was fully completed during the quarter, in addition to associated holding costs of the Company's properties.

# Oceanic Iron Ore Corp.

## Management's Discussion and Analysis of Financial Condition and Results of Operations Three months ended March 31, 2020 and 2019

---

The decrease in cash during the period of \$107,201 resulted from \$33,947 in interest paid on the Company's 2017 and 2018 convertible debentures, \$24,648 in payments associated with the Study at Hopes Advance and holding costs of the Company's properties, and \$48,606 operating cash outflow related to minimal general and administrative costs.

### Three-month period ended March 31, 2020 and 2019

The Company incurred a net income of \$41,588 during the three months ended March 31, 2020 (March 31, 2019 – net loss \$1,061,081). The most significant operating expenses incurred were consulting and management fees of \$58,750 (March 31, 2019 - \$58,750), and wages and benefits of \$16,975 (March 31, 2019 - \$23,414) and share based compensation of \$7,270 (March 31, 2019 - \$84,439). Consulting and management fees and wages and benefits remained consistent over the same period in the prior year. Further, the decrease in share-based compensation as compared to same period in the prior year as a result of a decreased number of stock options vesting during the current year as compared to the prior year.

Share-based compensation represents the Black-Scholes calculated value of stock options issued to directors, officers, consultants and employees which vested during the period.

During the three months ended March 31, 2020, the Company incurred \$55,682 of interest and accretion expense on the Company's convertible debentures (March 31, 2019 - \$80,957). On an annualized basis, interest and accretion expense increased from the prior year as a result of the issuance of the 2018 Debentures in November 2018 (refer to Convertible Debenture discussion below).

Furthermore, the Company recognized a \$216,076 gain on its convertible debentures derivative liabilities caused by the decrease in fair value of the convertible debenture derivative components (March 31, 2019 - loss \$777,281) largely driven by the underlying share price of the Company at the remeasurement date.

### **Liquidity and Capital Resources**

While the financial statements have been prepared on the basis that the Company will continue as a going concern, which contemplates the realization of assets and settlement of liabilities in the normal course of business as they come due, certain conditions and events result in a material uncertainty casting significant doubt on the validity of this assumption. For the three months ended March 31, 2020, the Company incurred a net income of \$41,588 and as at that date had an accumulated deficit of \$31,336,202. The Company's working capital deficit at March 31, 2020 was \$703,310.

The Company's ability to continue on a going concern basis for and beyond the next twelve months depends on its ability to successfully raise additional financing for continued operations and for the necessary capital expenditures required to achieve planned principal operations. The Company continues to pursue a number of options to improve its financial capacity, including securing a strategic partner to further advance the Hopes Advance project. While the Company has been successful in the past in obtaining financing, there is no assurance that it will be able to obtain adequate financing in the future or that such financing will be on terms acceptable to the Company. These material uncertainties cast significant doubt upon the Company's ability to continue as a going concern.

Factors that could affect the availability of financing include the Company's performance, the state of international debt and equity markets which have recently been adversely impacted by uncertainty arising

# Oceanic Iron Ore Corp.

## Management's Discussion and Analysis of Financial Condition and Results of Operations Three months ended March 31, 2020 and 2019

---

from the COVID-19 pandemic, investor perceptions and expectations, the retention of key executive management and the state of global financial and metals markets.

### Convertible Debentures – 2018 private placement

On November 29, 2018, the Company completed a non-brokered financing in an aggregate amount of \$1,812,500 through the issuance of convertible debentures (the "2018 Debentures"). The 2018 Debentures carry an interest rate of 8.5%, payable quarterly, with a maturity date of November 29, 2023.

The principal amount of the 2018 Debentures are convertible at any time at the election of the holder. The 2018 Debentures are convertible into Units, whereby each Unit consists of one common share of the Company and one share purchase warrant of the Company.

The conversion price during the first year of the 2018 Debentures was \$0.05 per Unit, increasing to \$0.10 per Unit for the remainder of the life of the 2018 Debentures.

Each share purchase warrant entitles the holder to purchase one common share of the Company at a price of \$0.05 per common share, expiring November 29, 2023. The 2018 Debentures are secured against the assets of the Company, ranking pari-passu with the 2017 Debenture holders.

The 2018 Debenture proceeds were used to fund the Study. The proceeds also continue to be used to fund ongoing negotiations with potential strategic partners, general claims maintenance, and corporate and working capital purposes.

Similar to the 2017 Debentures (discussed below), the conversion option is treated as a derivative liability and fair valued each reporting period, creating an accounting unrealized gain or loss. The convertible debentures are recognized as having two separate liability components. Firstly, the Units which are recognized as a derivative liability and fair valued each reporting period, and secondly the convertible debenture liability, which is fair valued at the time of issue, and then accreted to the face value over the life of the convertible debentures. At inception, the Company recognized an unrealized loss in the amount of \$2,202,578, which will be amortized over the life of the warrants. During the three months ended March 31, 2020, the Company recognized a \$174,317 gain to the Statement of Income (loss) and Comprehensive Income (loss) (March 31, 2019 – loss of \$773,725).

On October 24 and November 26, 2019, there was a partial conversion of the 2018 Debentures, whereby holders converted \$975,000 convertible debentures into Units comprising 19,500,000 common shares and 19,500,000 warrants. The remaining principal balance outstanding on the convertible debentures at March 31, 2020 was \$837,500 (December 31, 2019 - \$837,500).

### Convertible Debentures – 2017 Private Placement

On September 26, 2017, the Company completed a non-brokered financing of \$810,000 by way of issuance of convertible debentures (the "2017 Debentures"). The 2017 Debentures carry an interest rate of 8.5%, payable quarterly, with a maturity date of September 26, 2022. The 2017 Debentures are secured against the assets of the Company.

# Oceanic Iron Ore Corp.

## Management's Discussion and Analysis of Financial Condition and Results of Operations Three months ended March 31, 2020 and 2019

The principal amount of the 2017 Debentures are convertible at any time at the election of the holder. The 2017 Debentures are convertible into Units, whereby each Unit consists of one common share of the Company and one share purchase warrant of the Company. The conversion price during the first year of the 2017 Debentures was \$0.08 per Unit, increasing to \$0.10 per Unit for the remainder of the life of the 2017 Debentures. Each share purchase warrant entitles the holder to purchase one common share of the Company at a price of \$0.10 per common share, expiring September 26, 2022.

Proceeds from the 2017 Debentures have been used to fund ongoing negotiations with potential strategic partners, general claims maintenance, and corporate and working capital purposes.

In September 2018, there was a partial conversion of the 2017 Debentures, whereby one of the holders converted \$50,000 convertible debentures into Units comprising 625,000 common shares and 625,000 warrants. The remaining principal balance outstanding on the convertible debentures at March 31, 2020 was \$760,000 (December 31, 2019 - \$760,000).

During the three months ended March 31, 2020, the Company recognized a \$41,759 gain to the Statement of Income (loss) and Comprehensive Income (loss) (March 31, 2019 – loss of \$3,627).

### Off-Balance Sheet Arrangements

As at March 31, 2020, the Company had no off-balance sheet arrangements.

### Summary of Quarterly Results

Below is a summary of results for the eight most recently completed quarters in accordance with IFRS:

	March 31, 2020	December 31, 2019	September 30, 2019	June 30, 2019
Revenues ( <b>Note 1</b> )	\$ -	\$ -	\$ -	\$ -
Net income (loss)	\$ 41,588	\$ 1,267,992	\$ (99,833)	\$ (946,570)
Basic and diluted income (loss) per share	\$ 0.00	\$ 0.02	\$ (0.00)	\$ (0.01)

	March 31, 2019	December 31, 2018	September 30, 2018	June 30, 2018
Revenues ( <b>Note 1</b> )	\$ -	\$ -	\$ -	\$ -
Net income (loss)	\$ (1,061,081)	\$ (651,974)	\$ (141,583)	\$ 169,254
Basic and diluted income (loss) per share	\$ (0.02)	\$ (0.01)	\$ (0.00)	\$ 0.00

**Note 1** – As the Company has yet to achieve commercial production from its mineral related assets, the Company has no revenue to report during the financial reporting periods noted above.

# Oceanic Iron Ore Corp.

## Management's Discussion and Analysis of Financial Condition and Results of Operations Three months ended March 31, 2020 and 2019

---

The net income recognized in the quarter ended December 31, 2019 from the quarter ended September 30, 2019 was a result of the Company recognized a net gain of \$1,563,568 on its convertible debenture derivative liabilities. During the quarter December 31, 2019 an unrealized gain of \$2,331,000 was recognized due to fair value adjustments prior two partial conversions. An additional \$505,902 gain was recognized on settlement on partial conversion of debenture. These gains were partially offset by \$1,049,819 due to the acceleration of deferred loss recognized upon partial settlement and the unrealized loss of \$219,630 from the fair value adjustment of the reminder debenture at December 31, 2019. The increase in net loss from the quarter ended September 30, 2018 to September 30, 2019 is a result of the Company recognizing an unrealized loss on the 2018 convertible debentures that were issued in November 2018 due to the fair value adjustment to the derivative liability, largely driven by the increase in the Company's share price quarter over quarter. The net income recognized during the quarter ended June 30, 2018 is a result of the Company recognizing an unrealized gain on the convertible debenture generated from the fair value adjustment on the derivative liability. Refer to Results of Operations for the three-month period ended March 31, 2020 above for discussion of net operating loss incurred in Q1 2020.

### **Critical Accounting Policies and Critical Accounting Estimates**

Full disclosure of the Company's accounting policies and significant accounting judgments and estimation uncertainties in accordance with IFRS can be found in Note 4 of the audited annual financial statements for the year ended December 31, 2019.

### **Financial Instruments and Other Instruments**

#### *Financial Risk Management*

The Company is exposed in varying degrees to a variety of financial instrument related risks. The board approves and monitors the risk management processes.

#### Credit Risk

Credit risk arises from the potential for non-performance by counterparties of contractual financial obligations. The Company's exposure to credit risk is on its cash and cash equivalents and receivables. The Company has concentration of risk with respect to cash being held with one large Canadian financial institution. The Company's credit risk is mitigated by maintaining its financial liquid assets with highly reputable counterparties. The maximum exposure to credit risk is equal to the carrying value of the financial assets noted above.

#### Liquidity Risk

Liquidity risk is the risk that the Company cannot meet its obligations as they fall due. The Company's cash and cash equivalents are invested in business accounts and are available on demand. The Company manages liquidity risk by preparing and maintaining cash forecasts, which illustrate cash spent to date and the Company's cash needs over the short term. Contractual undiscounted cash flow requirements for financial liabilities as at March 31, 2020 and December 31, 2019 are presented below.

# Oceanic Iron Ore Corp.

## Management's Discussion and Analysis of Financial Condition and Results of Operations Three months ended March 31, 2020 and 2019

March 31, 2020

	Less than 1 year	1 - 3 years	4 - 5 years	Total
Accounts payable and accrued liabilities	\$ 350,607	\$ -	\$ -	\$ 350,607
Due to related parties	342,941	-	-	342,941
Convertible debenture - liability component	113,160	1,035,618	910,711	2,059,489
Advance royalty payable	400,000	400,000	400,000	1,200,000
	\$ 1,206,708	\$ 1,435,618	\$ 1,310,711	\$ 3,953,037

December 31, 2019

	Less than 1 year	1 - 3 years	4 - 5 years	Total
Accounts payable and accrued liabilities	\$ 279,555	\$ -	\$ -	\$ 279,555
Due to related parties	280,810	-	-	280,810
Convertible debenture - liability component	137,808	1,035,618	910,711	2,084,137
Advance royalty payable	400,000	400,000	400,000	1,200,000
	\$ 1,098,173	\$ 1,435,618	\$ 1,310,711	\$ 3,844,502

The Company's ability to continue operations in the normal course of business is dependent on several factors, including the ability to secure additional financing. In addition, the recoverability of the amounts shown for mineral properties are dependent upon the existence of economically recoverable reserves, the ability of the Company to obtain necessary financing to complete the development of those reserves and upon future profitable production, all of which are uncertain.

### Market Risk

Market risk is the risk that the fair market value of the Company's financial instruments will significantly fluctuate due to changes in market prices. The value of the financial instruments can be affected by changes in interest rates, foreign exchange rates and equity and commodity prices. The Company is exposed to market risk in its cash and cash equivalents. The Company manages market risk by investing funds with a reputable financial institution that provides competitive rates of return.

The Company's financial instruments are not subject to significant fluctuation due to changes in equity prices of investments included in commodity prices or foreign exchange rates.

The Company also invests surplus cash in fixed rate term deposits. It is the Company's policy to reduce interest rate risk over future cash flows through the use of instruments with a history of returns. A 1% change in interest rates would have a negligible impact on net loss and comprehensive loss.

### Fair value

Fair value is based on available public market information or, when such information is not available, estimated using present value techniques and assumptions concerning the amount and timing of future cash flows and discount rates which factor in the appropriate credit risk. The carrying values of cash and cash equivalents, receivables, restricted cash, accounts payable and accrued liabilities, and due to related parties approximate their fair values due to their short-term nature.

# Oceanic Iron Ore Corp.

## Management's Discussion and Analysis of Financial Condition and Results of Operations Three months ended March 31, 2020 and 2019

### Commitments

As part of the acquisition of the Ungava Bay mineral properties, commencing on November 30, 2011, Oceanic must pay advance net smelter royalty ("NSR") payments of \$200,000 per year, which will be credited against all future NSR payments payable from production.

The committed charges for the Company are as follows:

<b>March 31</b>	<b>NSR payments</b>	<b>Total commitments</b>
2020	\$ 400,000	\$ 400,000
2021	200,000	200,000
Thereafter	600,000	600,000
	<u>\$ 1,200,000</u>	<u>\$ 1,200,000</u>

### Related Party Transactions and Key Management Compensation

#### a) Key management compensation

Key management includes the Company's directors, Chief Executive Officer, Chief Financial Officer and President and Chief Operating Officer. Compensation awarded to key management is presented in the table below:

<b>Related Party</b>	<b>Relationship</b>	<b>Compensation Type*</b>	<b>Three months ended March 31, 2020</b>	<b>Three months ended March 31, 2019</b>
Steven Dean	Executive Chairman and Director	Share-based payments and Directors' fees	\$ 3,133	\$ 22,375
Bing Pan	Interim CEO	Share-based payments	1,830	13,095
Chris Batalha	CFO and Corporate Secretary	Wages, benefits, and share-based payments	16,830	28,095
Gordon Keep	Director	Share-based payments and Directors' fees	3,541	9,978
Hon. John D. Reynolds P.C.	Director	Share-based payments and Directors' fees	3,541	9,978
Cathy Chan	Director	Share-based payments and Directors' fees	3,541	9,978
Thomas Lau	Director	Share-based payments	678	4,880
			<u>\$ 33,093</u>	<u>\$ 98,379</u>

\*Share-based payments based on Options and RSUs granted to Individuals

As at March 31, 2020, the Company had the following balances owed to certain officers and directors of the Company:



# Oceanic Iron Ore Corp.

Management's Discussion and Analysis of Financial Condition and Results of Operations  
Three months ended March 31, 2020 and 2019

Related Party	Relationship	Compensation Type	Amount Payable (\$)
Gordon Keep	Director	Directors' fees	10,000
Hon. John D. Reynolds P.C.	Director	Directors' fees	17,500
Cathy Chan	Director	Directors' fees	20,000
Steven Dean**	Director	Consulting fees	184,583
Bing Pan*	Interim CEO	Consulting fees	5,000
Chris Batalha	CFO and Corporate Secretary	Wages and benefits	95,000

*\*\*These amounts relate to consulting fees due to Sirocco Advisory Services Ltd., a company controlled by Steven Dean.*

## b) Payments for services by related parties

During the three months ended March 31, 2020, the Company incurred corporate consulting fees of \$28,750 (March 31, 2019: \$28,750), to Sirocco Advisory Services Ltd., a company controlled by Steven Dean, a director and officer of the Company.

During the three months ended March 31, 2020, the Company incurred corporate consulting fees of \$15,000 (March 31, 2019: \$15,000) to Sinocan Consultant Hong Kong Ltd., a company controlled by Bing Pan, the Interim CEO of the Company.

During the three months ended March 31, 2020, the Company was charged \$5,107 on corporate overhead expenses by Artemis Gold Inc, a company with common management and directors, being Steven Dean and Chris Batalha. As of March 31, 2020, the Company owed \$10,858 to Artemis Gold Inc.

In September 2017, the Company completed non-brokered financing by way of issuance of convertible debentures. The convertible debentures are secured against the assets of the Company. The following table outlines the debentures held by officers and directors of the Company:

Related Party	Relationship	2017 Debentures Held (\$)
Steven Dean*	Executive Chairman	33,000
Gordon Keep	Director	50,000
Chris Batalha	CFO and Corporate Secretary	22,000

*\*Convertible Debentures are held through Sirocco Advisory Services, a company controlled by Steven Dean*

Related party transactions were made on terms equivalent to those that prevail in arm's length transactions.

## Subsequent Event

On April 7, 2020, the Company issued 179,998 common shares as a result of the settlement of RSUs.

## Outstanding Share Data

As at the date of this report, there were 92,735,848 common shares issued and outstanding.

# Oceanic Iron Ore Corp.

## Management's Discussion and Analysis of Financial Condition and Results of Operations Three months ended March 31, 2020 and 2019

---

As at the date of this report, there were 4,985,950 stock options, 20,125,000 common share purchase warrants, and 454,159 RSUs outstanding.

### **Risks and Uncertainties**

The Company is in the business of acquiring, exploring and, if warranted, developing and exploiting natural resource properties. At present, the mineral properties owned by the Company are located in Québec, Canada. Due to the nature of the Company's proposed business and the present stage of exploration of its mineral properties (which are primarily exploration), the following risk factors, among others, will apply:

#### **COVID-19**

During March 2020, several measures have been implemented in Canada and the rest of the world in response to the increased impact from novel coronavirus (COVID-19). We continue to operate our business at this time. While the impact of COVID-19 is expected to be temporary, the current circumstances are dynamic and the impacts of COVID-19 on our business operations cannot be reasonably estimated at this time and we anticipate this could have an adverse impact on our business, results of operations, financial position and cash flows in 2020. In particular, the valuation of the derivative liability which is measured at fair value using a combination of observable and unobservable market inputs, may be impacted during Q1 2020 or beyond.

As required by IFRS, we have not reflected these subsequent conditions in the measurement of our derivative liability at March 31, 2020

#### *Going Concern*

The financial statements have been prepared on a going concern basis, which assumes that the Company will continue in operation for the foreseeable future and will be able to realize its assets and discharge its liabilities in the normal course of business.

While the financial statements have been prepared on the basis that the Company will continue as a going concern, which contemplates the realization of assets and settlement of liabilities in the normal course of business as they come due, certain conditions and events result in material uncertainty casting significant doubt on the validity of this assumption. For the three months ended March 31, 2020, the Company incurred a net income of \$41,588 and as at that date had an accumulated deficit of \$31,336,202 and working capital deficit of \$703,310. The Company will need to raise additional funds in order to finance ongoing exploration, development and administrative expenses over the coming 12 months. The Company continues to pursue a number of options to improve its financial capacity, including securing a strategic partner to further advance the Hopes Advance project, and obtaining cash flow through other forms of financing. The success of raising such funds cannot be assured. Factors that could affect the availability of financing include the Company's performance, the state of international debt and equity markets which have recently been adversely impacted by uncertainty arising from the COVID-19 pandemic, investor perceptions and expectations, the retention of key executive management and the state of global financial and metals markets.

The financial statements do not reflect the adjustments to the carrying values of assets and liabilities and the reported expenses and statement of financial position classifications that would be necessary were the going concern assumption deemed to be inappropriate, and these adjustments could be material.

# Oceanic Iron Ore Corp.

Management's Discussion and Analysis of Financial Condition and Results of Operations  
Three months ended March 31, 2020 and 2019

---

## *Exploration and Development Risks*

The exploration for and development of mineral deposits involves significant risks which even a combination of careful evaluation, experience and knowledge may not eliminate. Few properties that are explored are ultimately developed into producing mines. Major expenses may be required to locate and establish mineral reserves, to develop metallurgical processes and to construct mining and processing facilities at a particular site. It is impossible to ensure that the exploration or development programs planned by the Company will result in a profitable commercial mining operation. Whether a mineral deposit will be commercially viable depends on a number of factors, some of which are: the particular attributes of the deposit, such as quantity and quality of the minerals and proximity to infrastructure; mineral prices, which are highly cyclical; and government regulations, including regulations relating to prices, taxes, royalties, land tenure, land use, importing and exporting of minerals and environmental protection. The exact effect of these factors cannot be accurately predicted but could have a material adverse effect upon the Company's operations.

There is no certainty that the expenditures made by the Company toward the search and evaluation of minerals will result in discoveries of mineral resources, Mineral Reserves or any other mineral occurrences.

## *Political Stability and Government Regulation Risks*

The operations of the Company are currently conducted in Québec, Canada. As such, the operations of the Company are exposed to various levels of political, economic and other risks and uncertainties. These risks and uncertainties include, but are not limited to: terrorism; extreme fluctuations in currency exchange rates; and changing political conditions, currency controls and governmental regulations.

Changes, if any, in mining or investment policies or shifts in political attitudes in Québec or Canada more broadly may adversely affect the operations or profitability of the Company. Operations may be affected in varying degrees by government regulations with respect to, but not limited to, restrictions on production, price controls, export controls, currency remittance, income taxes, expropriation of property, foreign investment, maintenance of claims, environmental legislation, land use, land claims of local people, water use and mine safety. For example, in 2013 the Government of Québec announced proposed changes to Québec's Mining Act, which were subsequently defeated in the Legislature. It is possible that amended changes may be proposed at some future date. Failure to comply strictly with applicable laws, regulations and local practices relating to mineral rights applications and tenure could result in loss, reduction or expropriation of entitlements, or the imposition of additional local or foreign parties as joint venture partners with carried or other interests.

The occurrence of these various factors and uncertainties cannot be accurately predicted and could have an adverse effect on the operations or profitability of the Company.

## *Insurance and Uninsured Risks*

The business of the Company is subject to a number of risks and hazards in general, including adverse environmental conditions, industrial accidents, labor disputes, unusual or unexpected geological conditions, ground or slope failures, changes in the regulatory environment and natural phenomena such as inclement weather conditions, floods and earthquakes. Such occurrences could result in damage to mineral properties or facilities and equipment, personal injury or death, environmental damage to properties of the Company or others, delays in mining, monetary losses and possible legal liability.

# Oceanic Iron Ore Corp.

## Management's Discussion and Analysis of Financial Condition and Results of Operations Three months ended March 31, 2020 and 2019

---

Although the Company may maintain insurance to protect against certain risks in such amounts as it considers being reasonable, its insurance may not cover all the potential risks associated with a mining company's operations. The Company may also be unable to maintain insurance to cover these risks at economically feasible premiums. Insurance coverage may not be available or may not be adequate to cover any resulting liability. Moreover, insurance against risks such as environmental pollution or other hazards as a result of exploration and production is not generally available to the Company or to other companies in the mining industry on acceptable terms. The Company might also become subject to liability for pollution or other hazards which it may not be insured against or which the Company may elect not to insure against because of premium costs or other reasons. Losses from these events may cause the Company to incur significant costs that could have a material adverse effect upon its financial performance and results of operations.

### *Environmental Risks and Hazards*

All phases of the Company's operations are subject to environmental regulation in the jurisdictions in which it operates. These regulations mandate, among other things, the maintenance of air and water quality standards and land reclamation. They also set forth limitations on the generation, transportation, storage and disposal of solid and hazardous waste. Environmental legislation is evolving in a manner that will require stricter standards and enforcement and involve increased fines and penalties for non-compliance, more stringent environmental assessments of proposed projects, and a heightened degree of responsibility for companies and their officers, directors and employees. There is no assurance that future changes in environmental regulation, if any, will not adversely affect the Company's operations. Environmental hazards may exist on properties in which the Company holds interests which are unknown to the Company at present and which have been caused by previous or existing owners or operators of the properties.

Failure to comply with applicable laws, regulations and permitting requirements may result in enforcement actions there under, including orders issued by regulatory or judicial authorities causing operations to cease or be curtailed, and may include corrective measures requiring capital expenditures, installation of additional equipment or remedial actions. Parties engaged in mining operations or in the exploration or development of mineral properties may be required to compensate those suffering loss or damage by reason of the mining activities and may have civil or criminal fines or penalties imposed for violations of applicable laws or regulations.

Amendments to current laws, regulations and permits governing operations and activities of mining and exploration companies, or more stringent implementation thereof, could have a material adverse impact on the Company and cause increases in exploration expenses, capital expenditures or require abandonment or delays in development of new mining properties.

### *Fluctuations in Metal Prices*

The price of the common shares, and the financial results and exploration, development and mining activities of the Company, may in the future be significantly and adversely affected by declines in the prices of iron ore and other metals or minerals. The prices of iron ore and other metals or minerals fluctuate widely and are affected by numerous factors beyond the control of the Company such as the sale or purchase of commodities by various central banks and financial institutions, interest rates, exchange rates, inflation or deflation, fluctuations in the value of the United States dollar and other foreign currencies, global and regional supply and demand, the political and economic conditions and production costs of major mineral-producing countries throughout the world, the cost of substitutes, inventory levels and carrying charges.

# Oceanic Iron Ore Corp.

## Management's Discussion and Analysis of Financial Condition and Results of Operations Three months ended March 31, 2020 and 2019

---

Future serious price declines in the market prices of iron ore or other metals or minerals could cause continued development of and commercial production from the properties in which the Company holds an interest to be impracticable. Depending on the prices of iron ore and other metals and minerals, cash flow from mining operations could not be sufficient and the Company may lose its interest in, or may be forced to sell, some of its properties. Future production from the Company's properties is dependent upon the prices of iron ore and other metals and minerals being adequate to make these properties economically viable.

In addition to adversely affecting the resource estimates of the Company and its financial condition, declining commodity prices can affect operations by requiring a reassessment of the feasibility of a particular project. Such a reassessment may be the result of a management decision or be required under financing arrangements related to a particular project. Even if a project is ultimately determined to be economically viable, the need to conduct such a reassessment may cause substantial delays or interrupt operations until the reassessment can be completed.

### *Key Personnel*

The Company is dependent upon the services of key executives, including the directors of the Company and a small number of highly skilled and experienced executives and personnel. Due to the relatively small size of the Company, the loss of these persons or the inability of the Company to attract and retain additional highly-skilled employees may adversely affect its business and future operations.

### *Share Price Volatility and Liquidity*

Publicly quoted securities are subject to a relatively high degree of price volatility. It may be anticipated that the quoted market for our shares will be subject to market trends generally, notwithstanding any potential success of us in creating sales and revenues. In addition, our shareholders may be unable to sell significant quantities of shares into the public trading markets without a significant reduction in the price of their shares, if at all.

### **Forward Looking Statements**

This document includes certain "Forward-Looking Statements" as that term is used in applicable securities law. All statements included herein, other than statements of historical fact, including, without limitation, statements regarding potential mineralization and resources, exploration results, and future plans and objectives of the Company, are forward-looking statements that involve various risks and uncertainties. In certain cases, forward-looking statements can be identified by the use of words such as "plans", "expects" or "does not expect", "scheduled", "believes", or variations of such words and phrases or statements that certain actions, events or results "potentially", "may", "could", "would", "might" or "will" be taken, occur or be achieved. There can be no assurance that such statements will prove to be accurate, and actual results could differ materially from those expressed or implied by such statements. Forward-looking statements are based on certain assumptions that management believes are reasonable at the time they are made. In making the forward-looking statements in this presentation, the Company has applied several material assumptions, including, but not limited to, the assumption that: (1) there being no significant disruptions affecting operations, whether due to labour/supply disruptions, damage to equipment or otherwise; (2) permitting, development, expansion and power supply proceeding on a basis consistent with the Company's current expectations; (3) certain price assumptions for iron ore; (4) prices for availability of natural gas, fuel oil, electricity, parts and equipment and other key supplies remaining consistent with current levels; (5) the accuracy of current mineral resource estimates on the Company's property; (6) labour and material costs increasing on a basis consistent with the Company's current expectations; and (7) the ability to achieve the required financing from equity markets, debt markets and/or a strategic partner/off-

# Oceanic Iron Ore Corp.

Management's Discussion and Analysis of Financial Condition and Results of Operations  
Three months ended March 31, 2020 and 2019

---

taker to facilitate the development and eventual construction of the Company's projects. Important factors that could cause actual results to differ materially from the Company's expectations are disclosed under the heading "Risks and Uncertainties" in this MD&A. Such factors include, among others, risks related to the ability of the Company to obtain necessary financing and adequate insurance; the economy generally; fluctuations in the currency markets; fluctuations in the spot and forward price of iron ore or certain other commodities (e.g., diesel fuel and electricity); changes in interest rates; disruption to the credit markets and delays in obtaining financing; the possibility of cost overruns or unanticipated expenses; employee relations. Accordingly, readers are advised not to place undue reliance on Forward-Looking Statements. Except as required under applicable securities legislation, the Company undertakes no obligation to publicly update or revise Forward-Looking Statements, whether as a result of new information, future events or otherwise.

Additional information relating to the Company is available on SEDAR at [www.sedar.com](http://www.sedar.com).